

5004-M-85 FLAME SAFEGUARD CONTROLLER

System Overview

Quanta-Flame 5004-M-85

A state-of-the-art flame safeguard controller designed for single burner boiler applications with one or two scanners. Unlike other flame safeguard controllers that require a multitude of amplifiers, programmers, and purge timers, the Preferred 5004-M-85 has just one processor with a built-in universal amplifier that accepts UV, IR, and self-checking UV scanner inputs, as well as flame rod inputs. In addition, Purge times and Main Trial For Ignition (MTFI) times are field-selectable.

Features Include

- Every unit interfaces to infrared, ultraviolet, ultraviolet self-check or flame rod sensors. Sensor specific plug-in amplifiers are not required
- Single or Dual Flame Sensors
- Field Selectable Purge Time
- Field Selectable Pilot Trial for Ignition (PTFI) Time
- Selectable running interlock short test
- DIP switch settings are burned into memory after four hours of operation
- RS485 Modbus Communication
- Local LCD display for status and troubleshooting
- Optional Remote Display (5004-216RN)
- Sequence Status Lights
- Jacks for direct flame strength measurement 0-5VDC
- Low Panel Profile
- Plug-in Field Wiring Terminals
- Field Selectable Check for Power Failure
- Field Selectable 10/15 sec Interrupted Pilot
- Field Selectable check for limits bypassed function
- Early Spark Termination
- Pilot Test Mode
- Optional 16 Point Annunciator (QA16)
- Remote/Local reset from lockout state

Controller Functions

False Flame Detection - The controller will lockout if flame is detected during Standby or Purge.

Safe Start Check - During every burner startup sequence, the controller performs hardware & software self-tests to verify it's internal circuitry is functioning properly. The controller verifies the safety relay, ignition relay, pilot relay, and the main fuel valve relays are functioning properly. If the "check for power failure" function is selected and power was interrupted during a firing cycle, upon power up the control will Lockout.

Check for Limits Bypassed - If the "Check for limits bypassed" function is selected, before beginning Purge, the controller ensures the Limits Made input is de-energized, and waits for up to 60 seconds for the Limits Made input to be de-energized. (The fan motor starter interlock and minimum air pressure switch should not be made before the fan is powered. This function will detect if these limits have been bypassed.)



Quanta-Flame 5004-M-85 Flame Safeguard Controller Chassis

Proof of Valve Closure (POVC) - The controller will lockout if the main fuel valves are not proven closed during Standby, Purge and Pilot Trial for Ignition (PTFI). The controller will also lockout if the main fuel valves close when the burner is firing.

Proven High Fire / Purge- Proves that the high fire position and purge air flow interlocks are made before Purge can begin, and requires these interlocks to be made throughout the Purge period. If these interlocks open during the Purge period for more than 30 seconds (cumulative), the controller will lockout. If running interlocks are not made continuously throughout the Purge period, the control will lockout after 5 minutes. This ensures a proper Purge cycle.

Proven Low Fire / Ignition - Proves the low fire position prior to Ignition and light off of the burner. If low fire proving switch is not made within 5 minutes. the control will Lockout.

Selectable Pilot Trial for Ignition (PTFI) Time - DIP switches allow selection of a 3, 5, or 10 second timing.

Early Spark Termination / Pilot Verification - The ignition transformer spark is de-energized at the end of PTFI while the pilot valve continues to be energized for 5 seconds before the main fuel valves are energized.

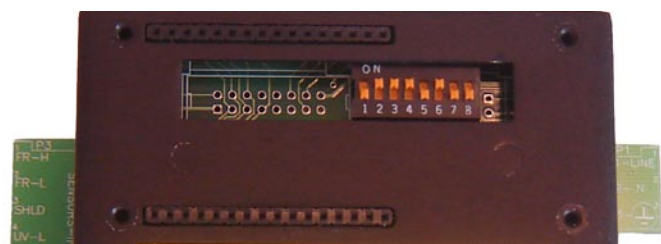

DIP switches used to configure the controller are located underneath the LCD display.

5004-M-85 FLAME SAFEGUARD CONTROLLER

System Overview

This ensures the sensor is not recognizing spark as a (false) flame and the pilot flame is stable without a spark, before energizing the main fuel valves.

Selectable Main Trial for Ignition (MTFI) Time - The default MTFI time is 10 seconds. Some No. 6 oil burners may require a 15 second MTFI to allow extra time for the cold oil to flow to the burner. Energizing terminal 27 changes the MTFI time from 10 seconds to 15 seconds.

Pilot Test Mode – In this mode, after the completion of PTFI, the ignition transformer is de-energized, the pilot valve remains energized, and the controller will not attempt to open the main fuel valves. If the flame sensor stops detecting a flame, the controller will lockout. This mode permits the technician to examine and adjust the pilot flame.

Specifications:

- Mechanical:** 7" L x 5" W x 2" D
- Weight:** 2 lbs
- Operating Temp:** -40° F to +140° F (-40° C to +60° C)
UV scanners -20° C to 60° C, IR scanner -30° C to 65° C
- Electrical:** Voltage: 120 VAC +10% - 15%, 50/60 Hz
- Power consumption:** 2 VA
- Flame Failure Response Time:** 2.5 to 3.5 seconds
- Purge Time:** 30, 60, 90, 150, 180, 300, 450, or 900 seconds (DIP switch selectable)

Pilot Trial for Ignition Time:

3, 5, or 10 seconds (DIP switch selectable)

Flame Sensor Inputs (2):

Infrared, Ultraviolet, Flame Rod

Controller Configuration:

Configuration of the controller is done by setting the DIP switches located under the LCD display.

DIP switch No. 1 sets the power-up response of the controller.

Switch 1	
ON	Controller locks out if power is interrupted after Trial for Ignition.
OFF	Controller recycles if power is interrupted after Trial for Ignition.

DIP switches 2 through 4 set the purge timing.

DIP switches 5 and 6 set the desired Pilot Trial for Ignition (PTFI) time.

DIP switch 7 activates the Limits Bypassed check. When DIP switch 7 is ON, the controller waits up to 60 seconds for the Limits Made input to de-energize. After 60 seconds, the control will lockout.

Purge Timer Configuration				
Switch 2	Switch 3	Switch 4	Purge Seconds	Explanation
ON	ON	ON	30	30 x 1 x 1 x 1
OFF	ON	ON	60	30 x 2 x 1 x 1
ON	OFF	ON	90	30 x 1 x 3 x 1
ON	ON	OFF	150	30 x 1 x 1 x 5
OFF	OFF	ON	180	30 x 2 x 3 x 1
OFF	ON	OFF	300	30 x 2 x 1 x 5
ON	OFF	OFF	450	30 x 1 x 3 x 5
OFF	OFF	OFF	900	30 x 2 x 3 x 5

5004-M-85 FLAME SAFEGUARD CONTROLLER

System Overview

Switch 5	Switch 6	Pilot Trial Seconds
OFF	OFF	3
ON	OFF	5
ON	ON	10

Switch 7	
ON	Controller goes into Lockout if Limits Made input is energized when Start command is powered.
OFF	Controller does not check to see if the Limits made input is powered at start-up.

When DIP switch 7 is OFF, the control will continue into Purge even if the Limits Made input is energized when the Start input is energized.

DIP switch 8 is used for configuring Modbus.

During normal operation: DIP Switch 8 MUST be OFF.

Note:

After 4 hours of continuous operation, ALL current DIP switch settings will be recorded in non-volatile memory. Subsequent DIP switch changes will be ignored.

Output Terminal Load Ratings:

Terminals 9 – 12

Modulation Sequencing: 2 A resistive

Terminals 18 – 19

Fan: 10 A resistive: ½ HP inductive

Terminal 21

Ignition Transformer: 10 A resistive, ¼ HP inductive

Terminal 22

Pilot Valve: 10 A resistive, ¼ HP inductive

Terminal 23

Main Fuel Valve: 10 A resistive, ¼ HP inductive

Terminal 29 – 30

Alarm Relay: 2 A resistive

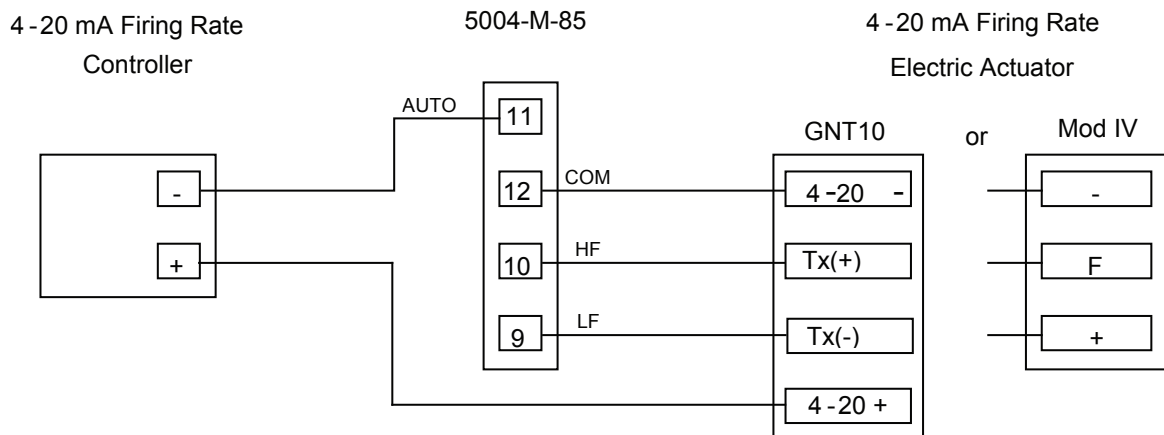
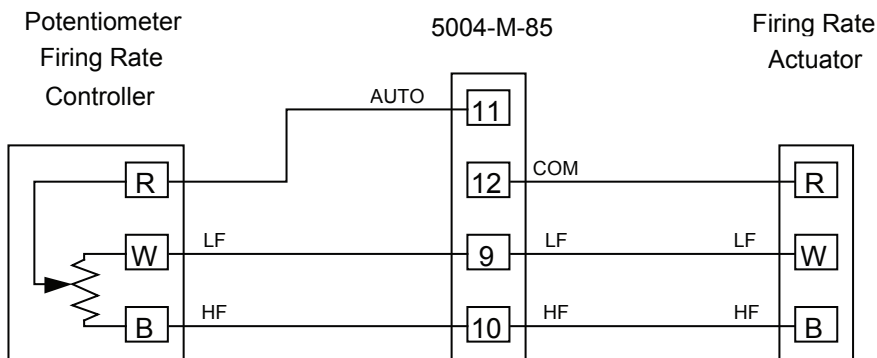

5004-M-85 Wiring for 0-135 Ohm, and 4-20 mA Firing Rate Outputs

5004-M-85 FLAME SAFEGUARD CONTROLLER

System Overview

Total connected 120 VAC load must not exceed 15 A.

Compatible Flame Sensors:

Flame Rod	
Ultraviolet, non self-checking	Model 5004-01
Infrared, non self-checking	Model 5004-11
Ultraviolet, non self-checking	Model 5002-01NC
Ultraviolet, self-checking	Model 5002-01
Infrared	Model 5002-11NC

Modbus Communications

The operation of the 5004-M-85 can be monitored via the RS485 Modbus communications link. Modbus also provides access to the Historical Data in the 5004-M-85: The last 6 Lockout reasons, burner run hours, and burner Start cycles.

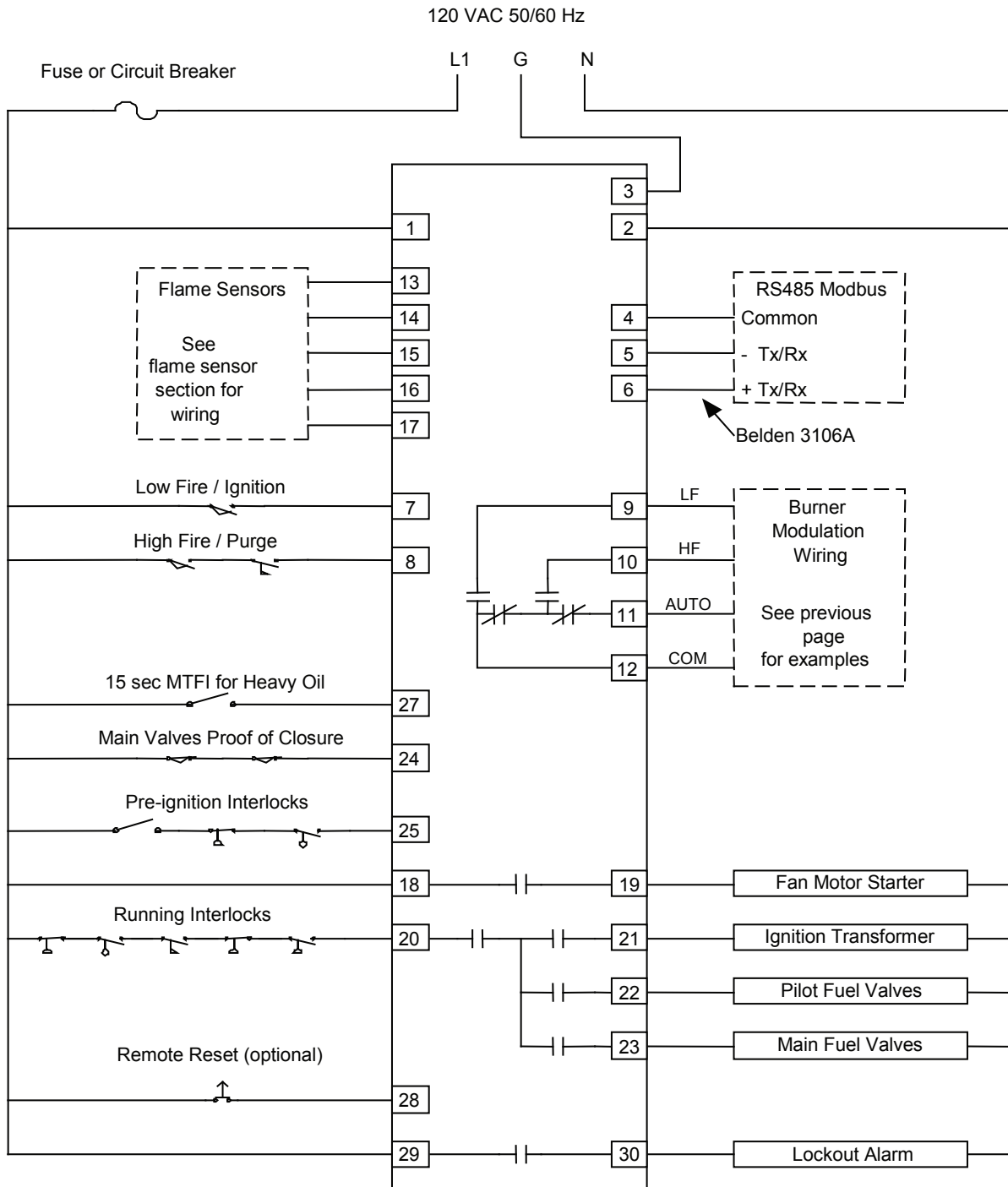

5004-M-85 External Wiring

5004-M-85 FLAME SAFEGUARD CONTROLLER

Suggested Specification

Modbus Description:

Electrical:	2 Wire RS485 half-duplex, non-isolated
Protocol:	RTU
Baud Rate:	4800
Start Bits	1
Stop Bits	1
Data Bits	8
Parity	None
Modbus Point Type:	Holding Register (400xx series)
Maximum Registers Requested/Poll	6
Modbus Functions supported:	Function 03: Read Multiple Holding Registers

Ordering Information

Description	Catalog Number
5004-M-85 Boiler FSG Controller	
FSG Controller w/ Integral Display. Universal UV, IR, UV Self-Check, and Flame Rod Input. DIP switch selectable purge, MTFI time, RS-485 Modbus Communications	5004-M-85

Suggested Specification:

1. Microprocessor Flame Safeguard Controller

Controller shall be U.L. recognized for single burner boiler applications. It shall accept inputs from one or two flame detectors without external circuitry. The controller shall be capable of accepting inputs from ultraviolet, infrared, self-checking ultraviolet, and flame rod detectors without changing controller hardware. Purge timing, Pilot Trial for Ignition (PTFI) timing, and other control functions shall be DIP switch selectable.

2. Flame Safeguard Controller Hardware

Controller and included flame amplifier circuitry shall be microprocessor-based and include the following as a minimum:

- Removable LCD display for status information and troubleshooting
- Optional remote display
- Sequence status LEDs on the controller faceplate including Start Limits (green), Fan On (yellow), Pilot (yellow), Main (yellow), Flame Fail (red), Safety Interlock (red), Alarm (red) Power (red), Flame (red), Low Fire (green), High Fire (red), Automatic (yellow)
- Plug-in field wiring terminals
- Test jacks for direct flame intensity measurement (0-5 VDC)

3. Flame Safeguard Functions

The controller shall cycle the burner from Standby, through Purge, supervised Pilot Trial for Ignition, Main Flame Trial for Ignition and Release to Modulate states. De-energization of pre-ignition interlocks, running interlocks, or loss of flame signal shall result in the safe shutdown of the burner. Additional control functions shall include:

- False Flame detection during Standby and Purge modes.
- Field selectable check for limits bypassed during startup.
- Field selectable Lockout or Recycle on loss of AC power.
- Field selectable Purge timing from 30 to 900 seconds (by DIP switch).
- Field selectable Pilot Trial for Ignition (PTFI) timing from 3 to 10 seconds (by DIP switch)
- Field selectable Main Trial for Ignition (MTFI) timing (by powering digital input)

4. Digital Communication

The flame safeguard controller shall be capable of Modbus RTU communications via RS-485 bus.

5. Manufacturer

The flame safeguard controller shall be model 5004-M-85 manufactured by Preferred Utilities Mfg. of Danbury, CT.