

Preferred Instruments

31-35 South Street, Danbury CT 06810
203-743-6741 www.preferredinstruments.com

JC-10D Bargraph Indicator with Alarm Relays and Flow Totalizer Installation & Operation Instructions

Description

The JC-10D Bargraph Indicator is a microprocessor-based Indicator / Alarm / Totalizer that can be field configured for a wide variety of applications. The instrument provides a highly visible backlit LCD display with easy to understand bargraph, scaled numeric display, and front panel Alarm messages. Bargraph Scaling, Alarm Setpoints, and Time Delays are all field selectable. The JC-10D can square root and Integrate the input with an 8 digit Totalizer Count for flow applications. The unit is constructed of a rugged polymer housing with a gasketed NEMA 12 faceplate.

Versatile

Field selectable input types: 2 or 4 wire 4-20 mA, 0 - 2.5 Vdc, J or K Thermocouple, and 10k ohm Thermistor. Thermistors and Thermocouples are linearized and cold junction compensated. For 4-20 mA or 0-2.5 Vdc input signals, the Process Variable display can be scaled to any desired display range. The Bargraph range can be set independently from the Input range. The 4-20 mA re-transmission output can be scaled independently as well. Adjustments are made directly from the faceplate of the instrument by scrolling through a user friendly, English language menu.

Alarm Sequences

The two (2) Alarms can be configured as HI-HI, HI, LO, or LO-LO Alarms with individually adjustable deadbands and time delays. Alarm adjustment is done in scaled engineering units, not percentages. Either of the two (2) relay outputs can be assigned to either of the Alarms or as a Common Alarm Output with Alarm Silencing logic. Each relay can also be configured as auto-reset or manual-reset.

RS485 Modbus Communications

The scaled Process Variable, Totalizer Count, and Alarm status are available via Modbus. Modbus can remotely silence alarms, reset Manual Reset relays, or Zero the Totalizer count.

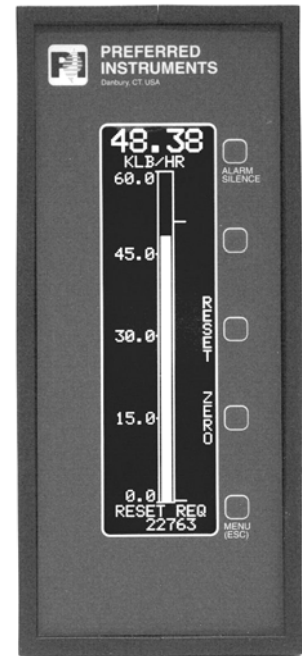

Table of Contents:

| | | | |
|--|---|---|----|
| Description..... | 1 | Menus | 7 |
| Ordering Information:..... | 1 | Setup..... | 9 |
| Specifications..... | 2 | Input Type, Display Units, Bargraph Setup | 9 |
| Operation | 2 | 4-20 mA or Vdc Input and Display Setup | 10 |
| Installation..... | 3 | Integrator / Totalizer Setup | 11 |
| Indicator Mounting: | 3 | 4-20 mA Output Scaling | 11 |
| Wiring Overview:..... | 4 | Alarm and Relay Output Setup..... | 12 |
| Power, Relay, RS485, 4-20 Output Wiring: | 4 | Modbus Communications..... | 14 |
| Input Signal Wiring:..... | 5 | | |

Ordering Information:

| Part Number | Description |
|-------------|---|
| JC-10D | Bargraph Indicator with Alarms and Totalizing |
| SDA-B6 | Alarm Bell, 6" dia, 85 db, 120 Vac |
| 21009 | ¼ amp Slo-Blo, 250 V,3AG fuse |
| 90265 | Replacement LCD display |
| 90248 | Replacement Mylar Keyboard Overlay |
| 90256 | Panel Mounting Gasket |

Specifications

Panel

Power Supply: 120Vac, +/- 15%, 50/60Hz, 15 VA
 Case Size: 8"H x 3.5"W x 7.5"D
 Enclosure Type: NEMA 12 faceplate, Indoor locations
 Ambient Temp.: +32° to 122° F
 Displays: High contrast LCD display
 4" high Bargraph, 0.5% resolution
 Bargraph Range: (field adjustable top and bottom values)
 Alarm Setpoints: (2) Alarm Setpoints.
 Each alarm has independently adjustable Deadband, time delay, and high or low alarm logic.
 Relay Logic: Individually selectable Source: Alarm 1, Alarm 2, Common
 Individually selectable Action: Alarm Silence
 Auto Reset
 Manual Reset

Inputs

Analog Input (1): Field selectable:
 *0-20 mA (100.5 ohm load)
 *0-2.5 Vdc
 *Type J or K thermocouple
 *Thermistor (25C/10k, 100C/817 ohms)
 Accuracy: 15 bit resolution:
 76 uV / bit: mA, Vdc, Thermistor
 0.005 %FS resolution
 2.4 uV/bit: Thermocouple
 0.005 %FS resolution
 Remote Silence: 120 Vac / 10 mA, Optically Isolated

Outputs

4-20 mA: 4-20 mA, 650 ohm maximum load (field adjustable scaling)
 Relay Outputs: (2) 10 A Resistive, 8 FLA, ½ Hp, 120 Vac
 Communications: Modbus, ASCII or RTU
 RS485, 1200 - 38400 Baud

Operation

The scaled Process Variable is continuously displayed at the top of the indicator. The Bargraph height varies in proportion to the Process Variable. The Bargraph top and bottom scaling can be adjusted via the **JC-10D** Menu to be any portion of the Process Variable range.

The **LCD display contrast** is adjustable via the MAIN Menu. Select the Main Menu item: **LCD CONTRAST**, and adjust the value until the display contrast suits the installed viewing angle.

The Alarms, Alarm Deadband, Alarm time delay, Relay outputs, and Totalizer are field configurable optional features. Consult the Setup Menus to determine which features are configured.

The **Alarm Setpoint** 'tic' mark(s) appear on the right side of the bargraph. When an Alarm is active, the bargraph and 'tic' mark blink, and the words **LOW-LOW**, **LOW**, **HIGH**, or **HIGH-HIGH** scroll across the display. Each alarm has an adjustable time delay that can be used to delay the triggering of the alarm. Each alarm also has an adjustable deadband.

If the Alarm Silence Relay feature is configured, press the **Alarm Silence button** to silence any audible alarms that are wired to the **JC-10D**.

If either relay output is configured for **Manual Reset** operation and the relay is activated, the words **RESET REQUIRED** scroll across the display. When the Alarm that triggered the relay clears, press the **RESET** button to de-activate the relay.

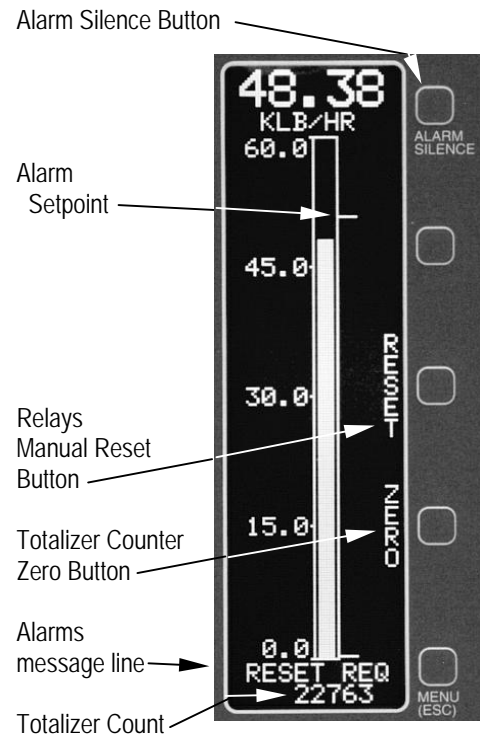

Operation (continued)

If the **Totalizer** feature is configured, an 8 digit Totalizer counter (0 - 99,999,999) appears on the bottom line of the display. The counter scaling is field configurable and is generally setup to be a multiple of 10 of the integrated value. For the 0-60,000 lb/hr display shown above, each count would typically be equal to either 10 lbs or 100 lbs. The current count is saved in non-volatile EEPROM memory every time the JC-10D powers down. The count automatically rolls over from 99,999,999 back to 0.

If the **Totalizer Count ZERO** button is configured, Press the **ZERO** button to reset the totalizer count to 0.

If the **JC-10D** is configured for a Thermocouple or Thermistor temperature sensor input, **OPEN SENSOR** will scroll across the display if the sensor or field wiring circuits become an open circuit. For a Thermistor temperature sensor configuration, **SHORTED SENSOR** will scroll across the display if the field wiring or the sensor circuits become a short circuit.

Installation

Indicator Mounting:

The JC-10D Indicator is designed for flush mounting in an enclosure located in an indoor NEMA 12 environment. The JC-10D should not be subjected to excessive vibration. Continuous operation is guaranteed within the 32-122 F (0-50C) ambient operating range.

- Cut a rectangular hole and drill two 5/32" mounting holes in the panel.
- If NEMA 12 water mist protection is required, apply the supplied gasket onto the panel.
- Remove the nuts from the JC-10D mounting studs.
NOTE: Hold the JC-10D faceplate in place after the nuts are removed.
- Put the JC-10D into the panel hole and re-install the nuts on the mounting studs from the inside of the panel.

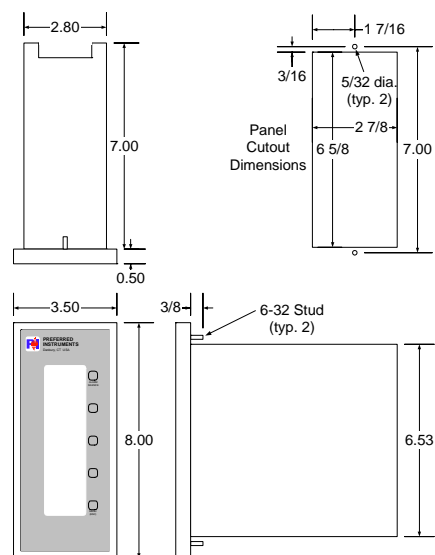

Wiring Overview:

Warning

Disconnect all sources of power before installing or servicing this equipment. Multiple Disconnects may be required.

All wiring must comply with all local and national electrical codes. Tighten all terminals to 4.4 in-lb. Wire must be stranded copper, 12-24 ga., 150V / 60 C insulation minimum. AC and DC wiring must be separated to prevent electrical noise coupling. Do not run AC and DC wires in the same conduits. Use shielded cables where shown, connect shields only where shown, insulate all other shields to prevent accidental grounding. Ignition transformer and motor VFD wiring are particularly noisy and should be kept away from all other AC and DC wiring.

- Terminals 1-9 are Line Voltage AC. Terminals 10-26 are low voltage DC.
- Relay contacts are shown with power removed from the JC-10D.
- Relay contacts have internal surge suppressors and are rated: 10 A resistive, 8 FLA / ½ Hp / 120 Vac
- All DC wiring circuits are isolated from Ground.
- All DC wiring '-', shield, and 'Common' terminals (12, 15, 17, 22, 24) are connected together internally.
- Thermocouple sensor wiring notes:
 - The wiring from the thermocouple to the JC-10D must be thermocouple extension wire. Do not use copper wire for any part of this wiring. Use the same wire type as the thermocouple: type J wire for a type J thermocouple.
 - The Red wire is the '-' for all thermocouple types. Connect the Red wire to the red or '-' screw in the thermocouple.
 - Avoid splicing the thermocouple extension wire. Each splice is a potential source of temperature error.
 - If shielded thermocouple wire is used, insulate the shield inside the thermocouple head to prevent shorting to ground.

Fuse: ¼ amp Slo-Blo, 250 V, 3AG (Preferred Instruments 21009, Littlefuse p/n 313 .250)

Caution: To reduce the risk of fire, only replace fuse with the same type.

Power, Relay, RS485, 4-20 Output Wiring:

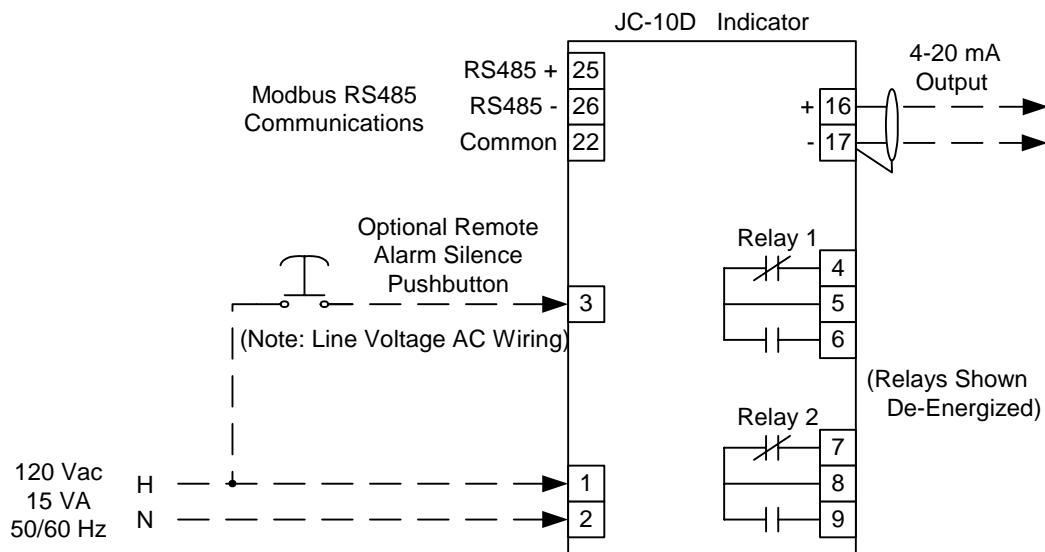

Isolation Notes:

All DC terminals (10-26) are isolated from ground and AC Neutral.

DC '-' terminals (12, 15, 17, 20, 22, 24) are all connected together internally.

RS485 terminals (25,26) are isolated from ground, but not from other DC circuits.

Input Signal Wiring:

Wire the Input Signal per one of the diagrams below. Set the INPUT TYPE in the Menu as noted in each diagram. Setting the INPUT TYPE in the Menu activates internal Load or Pull-up resistors as shown in the diagrams.

The Input Signal is isolated from Ground, but it is not isolated from the 4-20 mA Output or from the RS485 Communications, see notes above.

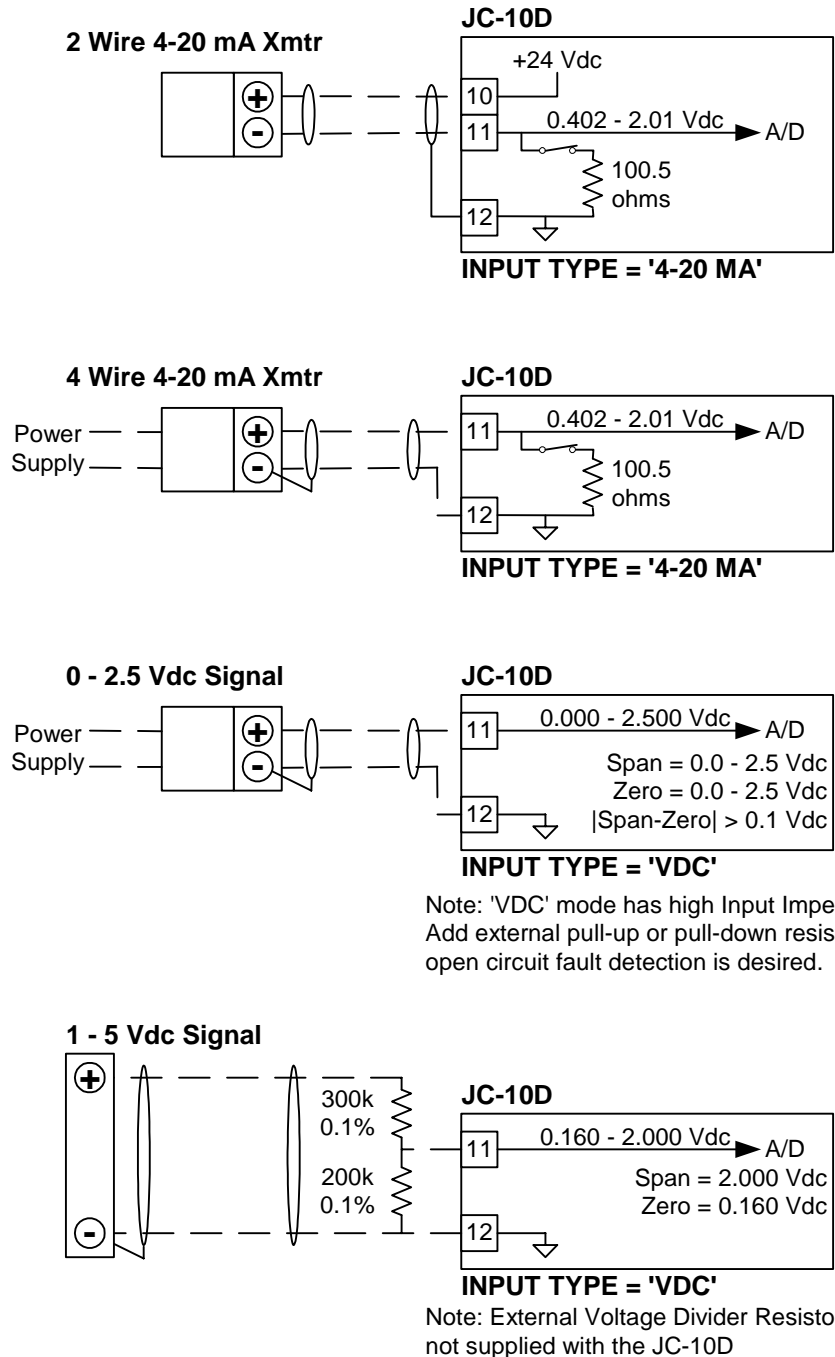

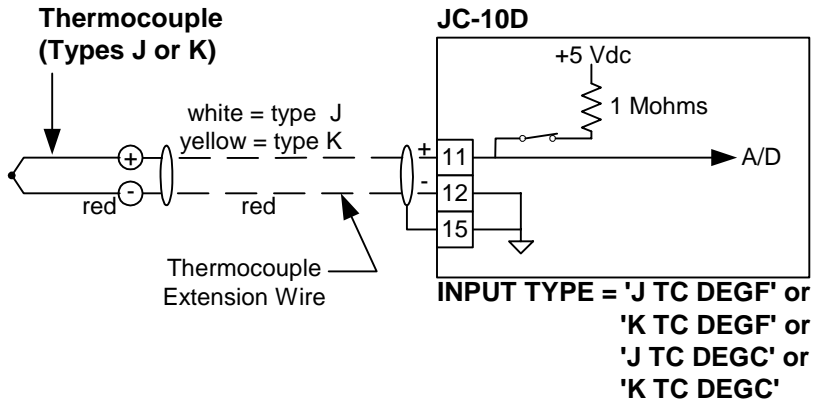

Thermocouple and Thermistor Field Wiring Notes:

- * Do not run in conduits with AC wiring.
- * Do not run in conduits with Ignition transformer or VFD motor wiring.
- * Can run in conduits with thermocouples, thermistors pots, 4-20 mA, and other 'quiet' DC wiring (not with pulser or solenoid wiring).
- * Un-Shielded Cable can be used if run in metallic conduit.

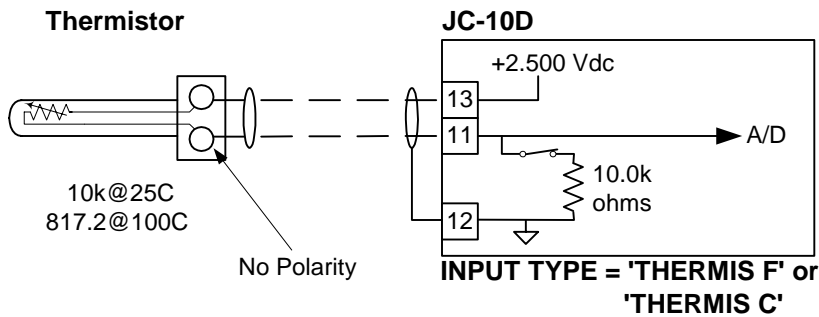

Menus

Input Type selection, Input scaling, Process Variable Display scaling, Alarm Setpoint and time delay adjustment, Bargraph scaling, LCD contrast adjustment and all other changes are made via the JC-10D Menus. This overview shows how to navigate through the JC-10D Menus and Sub-Menus. The detailed descriptions of each parameter will be discussed in the sections that follow.

From the bargraph display, press the MENU button to activate the MAIN MENU.

When the Menus are being displayed, the MENU button becomes the ESCape button. Pressing ESCape either cancels the current editing operation, or returns to the previous Menu, or exits the Main Menu and returns to the Bargraph display.

The items inside the box in the middle of the screen are the current Menu line item. Items above or below this box are previews of the next Menu lines.

Press UP or DOWN to scroll to the next Menu lines.

Press SELECT to edit the value of the current item or to activate the Sub-Menu.

Press ESC to exit a Menu or to cancel the editing of a value.

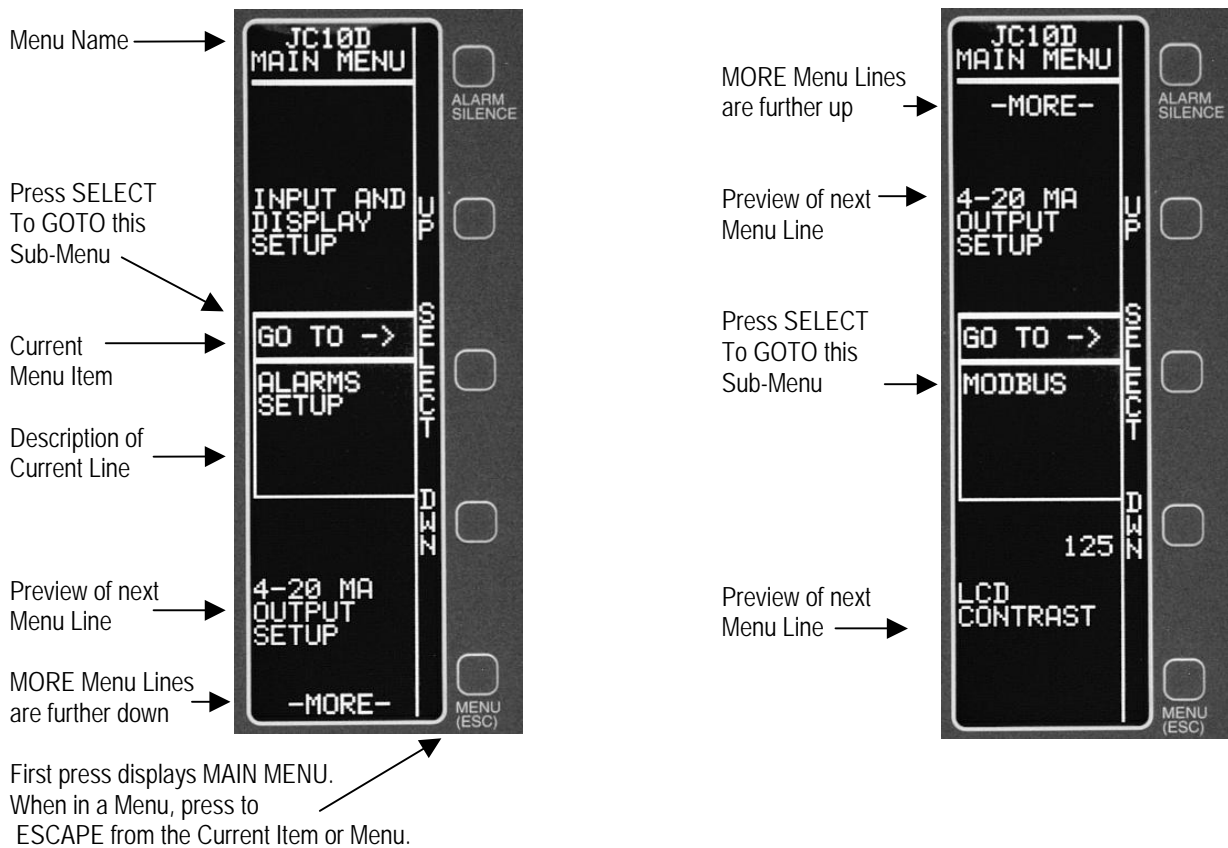

Menu Structure JC-10D Bargraph Indicator/Alarm

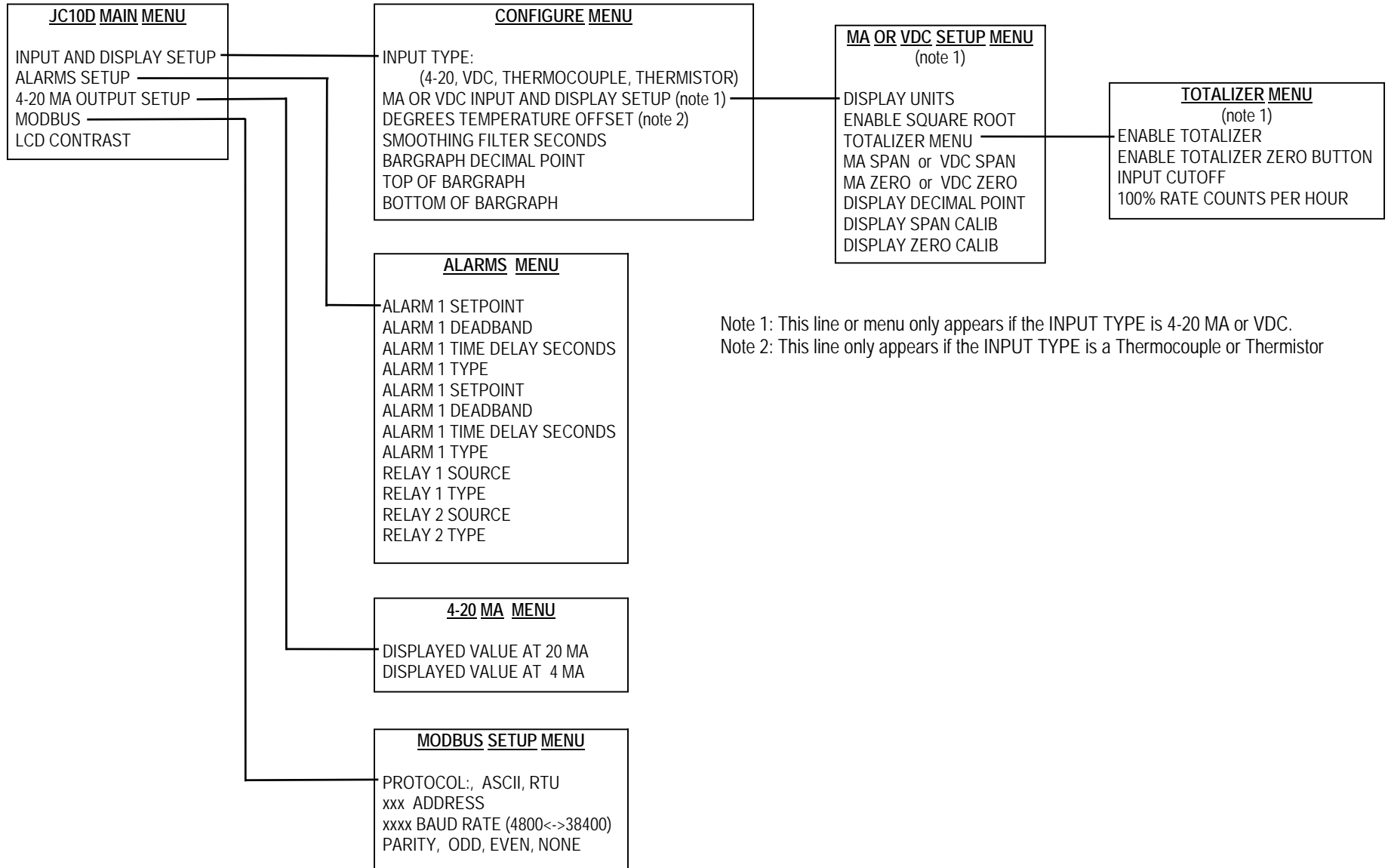

Setup

Input Type, Display Units, Bargraph Setup

For Thermocouple or Thermistor temperature sensor input signals, the following must be configured:

- Set the INPUT TYPE in the CONFIGURE Menu to the desired sensor / temperature units combination.
- Set the TOP OF BARGRAPH value to suit the normal operating range.
- Set the BOTTOM OF BARGRAPH value to suit the normal operating range.
- If desired, use the TEMPERATURE OFFSET value to adjust the Process Variable value to correct for sensor errors.
- The Process Variable will be displayed in the selected deg. F or deg. C units in #### format (no decimal point).

For 4-20 mA or 0-2.5 Vdc input signals, the following must be configured:

- Set the INPUT TYPE in the CONFIGURE Menu to 4-20 MA or VDC.
- Select the MA OR VDC SETUP MENU and setup all of the values in this sub-menu.
- If the Totalizer feature is desired, select the TOTALIZER sub-menu and setup all of the values in this sub-menu.
- Set the BARGRAPH DECIMAL POINT to suit the input sensor calibration.
- Set the TOP OF BARGRAPH value to suit the normal operating range.
- Set the BOTTOM OF BARGRAPH value to suit the normal operating range.

Note: Changing the INPUT TYPE automatically re-sets the Bargraph Scaling, Alarm Setpoints, 4-20 mA Output scaling, and mA/Vdc input setup values to pre-defined default values. Changing the INPUT TYPE over-writes any previously entered data.

| Actual | Default | Max. | Min. | CONFIGURE Menu Items |
|--------|-------------------|-------------------|-------------------|---|
| | 4-20 MA | | | INPUT TYPE <u>Choices:</u> 4-20 MA Go to MA OR VDC INPUT AND DISPLAY SETUP to setup. VDC Go to MA OR VDC INPUT AND DISPLAY SETUP to setup. J TC DEGF Type J Thermocouple, 1100 to -100 degrees Fahrenheit range. K TC DEGF Type K Thermocouple, 2200 to -100 degrees Fahrenheit range. THERMIS F Thermistor (10k ohm/25C), 300 to -50 degrees Fahrenheit range. J TC DEGC Type J Thermocouple, 550 to -75 degrees Centigrade range. K TC DEGC Type K Thermocouple, 1200 to -75 degrees Centigrade range. THERMIS C Thermistor (10k ohm/25C), 150 to -50 degrees Centigrade range. |
| | 0 | +15 | -15 | DEG, TEMPERATURE OFFSET The displayed value is offset from the measured value by this amount for all temperatures. Used to calibrate out minor temperature differences due to sensor errors. The units are F or C, as selected above. NOTE: This line is only displayed if the INPUT TYPE is a Thermocouple or Thermistor |
| | 0.5 | 5.0 | 0.5 | SECONDS, SMOOTHING FILTER Dampens (smoothes) rapid display variations. Larger values = more damping. Smaller values = less damping. |
| | #### | ##.## | #### | BARGRAPH DISPLAY DECIMAL POINT Determines where the fixed decimal point appears in the bargraph scale values. This selection limits the range of adjustment of the TOP and BOTTOM values: #### 20000 to -9999, default = 100 ##.# 999.9 to -99.9, default = 100.0 ##.## 99.99 to -9.99, default = 10.00 NOTE: This line is only displayed if the INPUT TYPE is 4-20 MA or VDC. Thermocouple or Thermistor INPUT TYPE's for the decimal to #### format. |
| | see Decimal Point | see Decimal Point | see Decimal Point | TOP OF BARGRAPH This is the scale value at the top of the bargraph. See the BARGRAPH DISPLAY DECIMAL POINT above for the Default, Max., and Min. values. The difference between TOP and BOTTOM should be evenly divisible by 4 for an easy-to-read bargraph display scaling. |
| | see Decimal Point | see Decimal Point | see Decimal Point | BOTTOM OF BARGRAPH This is the scale value at the top of the bargraph. See the BARGRAPH DISPLAY DECIMAL POINT above for the Default, Max., and Min. values. The difference between TOP and BOTTOM should be evenly divisible by 4 for an easy-to-read bargraph display scaling. |

4-20 mA or Vdc Input and Display Setup

This sub-menu will not be displayed if the INPUT TYPE is setup as a Thermocouple or as a Thermistor.

Setup all values in this sub-menu to match the electrical signal input range and to match the Process Variable display calibration range. The JC-10D converts the input current or voltage to the Process Variable Display in the following sequence:

- 1) Convert the current/voltage to an internal 0-100% input signal using the MA (or VDC) SPAN and MA (or VDC) ZERO.
- 2) If enabled, take the square root of the internal 0-100% input signal and re-scale the result to 0-100%.
- 3) Convert the 0-100% input signal to the Process Variable displayed value (in engineering units) using the DISPLAY DECIMAL POINT, DISPLAY SPAN CALIB, and DISPLAY ZERO CALIB values.

Select the desired DISPLAY UNITS message to be displayed underneath the Process Variable display.

Note: Changing the INPUT TYPE automatically re-sets the Bargraph Scaling, Alarm Setpoints, 4-20 mA Output scaling, and mA/Vdc input setup values to pre-defined default values. Changing the INPUT TYPE over-writes any previously entered data.

| Actual | Default | Max. | Min. | MA OR VDC Menu Items |
|--------|-------------------------|-------------------------|-------------------------|--|
| | PERCENT | | | DISPLAY UNITS Choices: PERCENT, DEG. F, DEG. C, DRAFT"H20, INCH H20, INCHES HG, PSI, PSIA, PSID, KPA, BAR, INCHES, FEET, CENTMETER, METERS, GALLONS, LITERS, LBS, TONS, KILOGRAMS, LB/HR, KLB/HR, GPH, GPM, KGPM, MGD, CFM, KCFM, HZ, RPM, FPM, AMPS, KAMPS, KVARs, KWATTS, MWATTS, blank |
| | NO | YES | NO | ENABLE SQUARE ROOT If enabled, the square root of the 0-100% input signal is used for the Display, Bargraph, and Totalizer. Input signals below zero are treated as zero. Example: 4-20 mA input, 0-1000 GPM display scaling; 4.64 mA (4%) -> 200 GPM (20%), 11.84 mA (49%) -> 700 GPM (70%), 16.96 mA (81%) -> 900 GPM (90%), 4 mA = 0 GPM, 20 mA = 1000 GPM |
| | 20.000mA 2.000 Vdc | 20.000 2.500 | 0.000 0.000 | MA SPAN or VDC SPAN Used to scale the input current or voltage to a 0-100% Input Signal. When the current (or voltage) equals MA SPAN (or VDC SPAN), the Input Signal = 100%. The 0-100% Input Signal is then scaled by the DISPLAY SPAN and DISPLAY ZERO to calculate the Process Variable Display value. MA SPAN (or VDC SPAN) can be greater than MA ZERO (or VDC ZERO) for reverse ranged transmitters (ie, 20-4 mA instead of 4-20 mA). |
| | 20.000mA 2.000 Vdc | 20.000 2.500 | 0.000 0.000 | MA ZERO or VDC ZERO Used to scale the input current or voltage to a 0-100% Input Signal. When the current (or voltage) equals MA ZERO (or VDC ZERO), the Input Signal = 100%. The 0-100% Input Signal is then scaled by the DISPLAY SPAN and DISPLAY ZERO to calculate the Process Variable Display value. MA SPAN (or VDC SPAN) can be greater than MA ZERO (or VDC ZERO) for reverse ranged transmitters (ie, 20-4 mA instead of 4-20 mA). |
| | #### | #.### | #### | DISPLAY DECIMAL POINT The fixed decimal point location in the Process Variable Display. This selection limits the range of adjustment of DISPLAY SPAN and DISPLAY ZERO values to the following: #### 20000 to -9999, default = 100 ###.# 999.9 to -999.9, default = 100.0 ##.## 99.99 to -99.99, default = 10.00 #.### 9.999 to -9.999, default = 1.000 |
| | see Decimal Point | see Decimal Point | see Decimal Point | DISPLAY SPAN CALIB Used to scale the 0-100% input signal to the Process Variable Display value. The Process Variable Display equals the DISPLAY SPAN CALIB value when the Input Signal is equal to 100% (that is, the MA SPAN or VDC SPAN). If required, the Display Span value can be less than the Display Zero value. |
| | see Decimal Point | see Decimal Point | see Decimal Point | DISPLAY ZERO CALIB Used to scale the 0-100% input signal to the Process Variable Display value. The Process Variable Display equals the DISPLAY ZERO CALIB value when the Input Signal is equal to 0% (that is, the MA ZERO or VDC ZERO). If required, the Display Span value can be less than the Display Zero value. |

Integrator / Totalizer Setup

This sub-menu will not be displayed if the INPUT TYPE is setup as a Thermocouple or as a Thermistor.

As described below, setup the values in this menu to control the characteristics of the Integrator/Totalizer feature of the JC-10D.

| Actual | Default | Max. | Min. | TOTALIZER SETUP Menu Items |
|--------|---------|---------------------|------|---|
| | NO | YES | NO | ENABLE TOTALIZER If enabled, the JC-10D integrates the 0-100% Input Signal (after optional square rooting) and Totalizes an 8 digit counter in proportion to the 100% RATE COUNTS PER HOUR value in this menu. The Totalizer Count is displayed on the bottom line of the JC-10D display. The Totalizer Count is saved in non-volatile memory during each JC-10D power-down cycle. |
| | NO | YES | NO | ENABLE TOTALIZER ZERO BUTTON If enabled, the front panel ZERO button is displayed. Pressing the ZERO button resets the Totalizer Count to zero. |
| | 0 | 90% of Display Span | 0 | INPUT CUTOFF When the Process Variable is less than the INPUT CUTOFF, the Integrator / Totalizer ignores the Input Signal and holds at the last value. The INPUT CUTOFF value is scaled to the same units as the Process Variable Display. This feature is used to prevent false totalizing due to flow transmitter 4.00 mA calibration drift. |
| | 1000 | 20000 | 60 | 100% RATE COUNTS PER HOUR This value determines the Totalizer Count scaling. When the Input Signal equals 100% (after optional square rooting), the Totalizer Count increases at the rate of the '100% RATE COUNTS PER HOUR' value. Generally, this value is set to a multiple of 10 of the flow transmitter full scale flow calibration value. Example: 4-20 mA flow meter calibrated for 0-25,000 lbs/hr of steam. 100% RATE COUNTS PER HOUR is set to 2500, each Count equals 10 lbs. |

4-20 mA Output Scaling

Adjust for the desired 4-20 mA output scaling. The Maximum and Minimum values are limited to the current range limits of the Process Variable Display. The 4-20 output can be setup for any portion of the Process Variable range. The value for 20 mA can be smaller than the value for 4 mA (20-4 mA applications).

| Actual | Default | Max. | Min. | 4-20 MA OUTPUT Menu Items |
|--------|--------------|--------------|--------------|--|
| | Display Span | Display Span | Display Zero | DISPLAYED VALUE AT 20 MA This is the Process Variable Display value that will drive the output to 20 mA. |
| | 0 | Display Span | Display Zero | DISPLAYED VALUE AT 4 MA This is the Process Variable Display value that will drive the output to 4 mA. |

Alarm and Relay Output Setup

As described below, setup these menu items to configure the Alarms and Relay outputs.

Note: Changing the INPUT TYPE automatically re-sets the Bargraph Scaling, Alarm Setpoints, 4-20 mA Output scaling, and mA/Vdc input setup values to pre-defined default values. Changing the INPUT TYPE over-writes any previously entered data.

| Actual | Default | Max. | Min. | ALARMS SETUP Menu Items |
|--------|--------------|----------------------|--------------|---|
| | Display Span | Display Span | Display Zero | ALARM 1 SETPOINT The Setpoint for Alarm 1. The Setpoint value is displayed in the same units and scaling as the Process Variable. See ALARM TYPE below for more details. |
| | 0 | 90% of Display Range | 0 | ALARM 1 DEADBAND The Deadband for Alarm 1. The Deadband value is displayed in the same units and scaling as the Process Variable. See ALARM TYPE below for more details. |
| | 5 | 3600 | 0 | ALARM 1 TIME DELAY SECONDS The Process Variable must be beyond the Setpoint for more than xxx seconds before the JC-10D will trigger this Alarm. |
| | HI | HI-HI | LOW-LOW | ALARM 1 TYPE Choices: LOW-LOW, LOW, HI, HI-HI PV=Process Variable, SP=Setpoint, DB=Deadband, TD=Time Delay LOW and LOW-LOW Alarm Type Logic: (PV < SP) for more than TD seconds: Turns Alarm ON (PV > (SP + DB)) : Turns Alarm OFF HI and HI-HI Alarm Type Logic: (PV > SP) for more than TD seconds: Turns Alarm ON (PV < (SP - DB)) : Turns Alarm OFF NOTE: LOW and LOW-LOW use the same logic, HI and HI-HI use the same logic. The only difference is the message shown on the display (LOW versus LOW-LOW, HIGH versus HIGH-HIGH). |
| | Display Zero | Display Span | Display Zero | ALARM 2 SETPOINT The Setpoint for Alarm 2. See ALARM 1 SETPOINT description above. |
| | 0 | 90% of Display Range | 0 | ALARM 2 DEADBAND The Deadband for Alarm 2. See ALARM 1 DEADBAND description above. |
| | 5 | 3600 | 0 | ALARM 2 TIME DELAY SECONDS See ALARM 1 TIME DELAY SECONDS description above. |
| | LOW | HI-HI | LOW-LOW | ALARM 2 TYPE Choices: LOW-LOW, LOW, HI, HI-HI See ALARM 1 TYPE description above. |

Alarm and Relay Output Setup Menu is continued on the next page.

Alarm and Relay Output Setup (continued)

| Actual | Default | Max. | Min. | ALARMS SETUP Menu Items |
|--------|-----------|------|------|---|
| | COMMON | | | RELAY 1 SOURCE Choices: COMMON, ALARM 1, ALARM 2 COMMON: Either ALARM 1 or ALARM 2 will activate this relay. ALARM 1: ALARM 1 will activate this relay. ALARM 2: ALARM 2 will activate this relay. |
| | ALMSILENC | | | RELAY 1 TYPE Choices: ALMSILENC, AUTORESET, MANRESET AUTORESET: If either Source is ON, the Relay is ON. If the Source(s) are OFF, the Relay is OFF. ALMSILENC: When either Source changes to ON, the Relay turns ON. When either Source changes to OFF, the Relay turns OFF. When the Relay is ON: Pressing the ALARM SILENCE button, or changing the Remote Alarm Silence Input from OFF to ON will turn OFF the Relay. The relay re-activates when either Source changes to ON. MANRESET: If either Source is ON, the Relay is ON. When the source turns OFF, the relay remains ON until the RESET button is pressed. If Source = COMMON, both must be OFF. |
| | ALARM1 | | | RELAY 2 SOURCE See RELAY 1 SOURCE description above. |
| | AUTORESET | | | RELAY 2 TYPE See RELAY 1 TYPE description above. |

Modbus Communications

Field Selectable via the MODBUS menu:

Protocol: RTU or ASCII

Address: 1-247

Baud: 1200, 4800, 9600, 19200, 38400

Parity: Odd, Even, None ('No Parity' requires 2 Stop bits)

Register Format: Signed Integers, -32767 to + 32767

Modbus Commands: 01 Read Coils, 03 Read Holding Registers, 05 Write Single Coil, 06 Write Single Holding Register
(A maximum of 10 coils or registers can be read in a single poll)

| Coil | | 0 = | 1 = | Description |
|-----------------|----|-----|-------------|-----------------------------------|
| 400 | RW | | Silenced | Alarm Silence |
| 401 | WO | | Reset | Relay(s) Manual Reset |
| 402 | RO | | Reset Req'd | Relay(s) latched, Reset Required |
| 403 | WO | | Zero Count | Zero Totalizer Count (if enabled) |
| 404 | RO | | In Alarm | Alarm 1 |
| 405 | RO | | In Alarm | Alarm 2 |
| 406 | RO | | Energized | Relay 1 |
| 407 | RO | | Energized | Relay 2 |
| | | | | |
| Register | | | | |
| 40450 | RO | | | Process Variable |
| 40451 | RW | | | Lower 16 bits of Totalizer Count |
| 40452 | RW | | | Upper 16 bits of Totalizer Count |

Modbus Register Scaling

Process Variable: The Modbus value has an 'implied decimal point' in the position configured by the JC10D menu. If the JC-10D display is configured as ##.##, and the displayed value is 13.47, then the Modbus value would be 1347.

Totalizer Count: The combination of registers 40451 and 40452 is the 32 bit totalizer count. If register 40452 contains 137, and register 40451 contains 34756; then the totalizer count is:

$$(137 * 65536) + 34756 = 9,013,188$$

The Count range is 0 - 99,999,999 (decimal) and automatically rolls over from 99,999,999 back to 0.

Preferred Instruments

31-35 South Street, Danbury, CT 06810
203-743-6741 www.preferredinstruments.com