

# SHAFT POSITION SENSOR

Model SPS

- 0 - 100% Boiler Firing Rate Signal
- Sensor used by Oxygen Trim, Furnace Draft or other control that require a boiler load index
- 45 to 160 degree stroke input allows installation flexibility

The Shaft Position Sensor (SPS) is a general-purpose feedback pot for applications that require firing rate feedback as a basis for establishing setpoints for other control loops such as Oxygen Trim or FGR Flow.

## Specification

Stroke: 45 to 160 degree  
Output: 1K ohm Potentiometer  
Enclosure: NEMA 12  
Linkage Rod: 5/16" x 3' linkage  
Swivel Joint  
Connection: 1/4 - 20 threaded

## Ordering Information

Model SPS



Shaft Position Sensor Model SPS

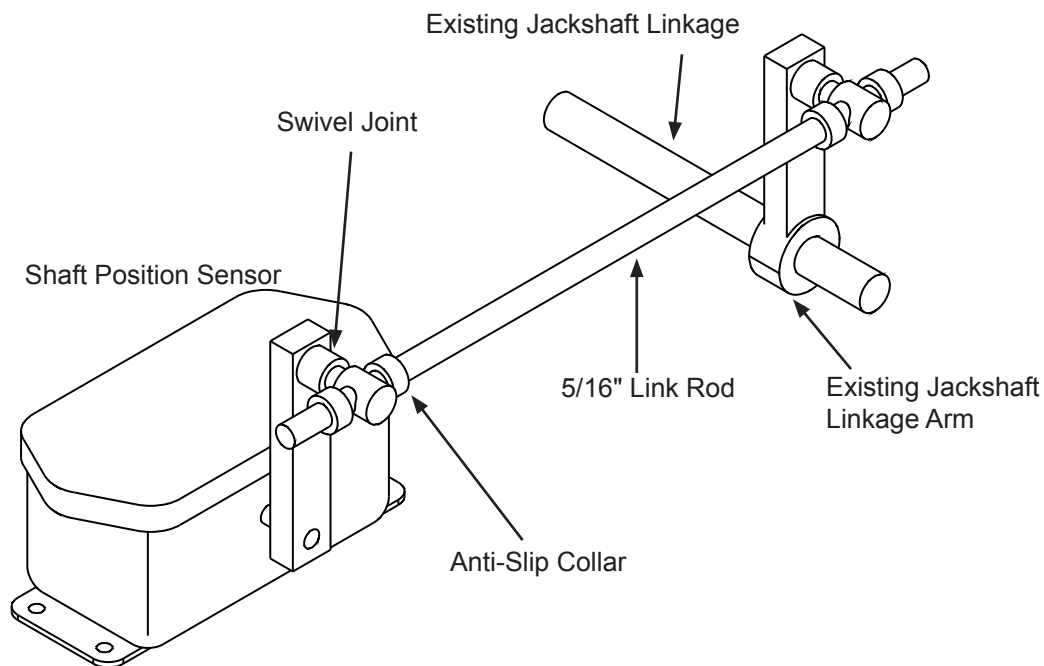

Typical Linkage Assembly